





The Right Tool



Many clinicians go through their workweek without touching a tool. They see something that needs doing on a chair, issue a decree, and magically the work is done. There are others who can't wait to get their hands dirty; they feel there is not a chair on the face of the earth that wouldn't benefit from their attention. Between the two, lays the technician's nightmare, the ones they fear, the ones who know enough to do damage - and not enough to realize it.

This information will help you understand tools commonly used on wheelchairs and perhaps endear yourself to the technicians you work with, as a therapist who is kind to chairs.

A question I am routinely asked is "What tools do I need to make the most common adjustments The answer is constantly changing depending on the vagaries of the market. Here is my best estimate.

Tool	Appearance	Fastener	Imperial	Metric	Comment
Wrench			7/16" 1/2" 3/4"	10mm 11mm 12mm 13mm 19mm	(11mm and 19mm are the same as 7/16" and 3/4")
Sockets			7/16" 1/2" 3/4"	10mm 11mm 12mm 13mm 19mm	(11mm and 19mm are the same as 7/16" and 3/4")

Wrenches and sockets are the basic tool for chair maintenance. Often you need to have two of each size, one to hold the bolt head and the other to turn the nut (or vice versa). If you have a socket and ratchet of the appropriate size you can use it instead of one of the wrenches. Make sure you use the proper size wrench Only use adjustable wrenches when you don't have a real one in the proper size.

Adjustable wrench			0-1 1/4"		Seem like a great idea but should only be used when a proper size wrench or socket is unavailable. If the wrench is not used properly the bolts or nuts will round off.
-------------------	---	---	----------	--	---



Slide wrench all the way on to nut, (unlike photo) so there is full contact at the back of the jaws. Then tighten the wrench thumbscrew so there's no play at all in the jaws. Always turn the wrench handle toward the lower (or fixed) jaw, never away from it.

Allen Keys			1/8" 5/32" 3/16"	2mm to 8mm	Metric and Imperial are hard to distinguish. Ensure a really good fit between wrench and bolt to prevent rounding.
------------	---	---	------------------------	------------	--

Allen bolts are popular fasteners with wheelchair manufacturers and a set of metric and imperial keys will help in making adjustments. The most common Allen keys are "L" shaped and both ends fit the same size bolt. Stick the short end in and you have added leverage for loosening stuck bolts. Sticking the long end in will allow you to remove loose bolts quickly. If you don't mind carrying quite a few tools "T" handle Allen keys are nice to use. To condense your tool bag get some Allen bits to fit your multi bit screwdriver. Or get a hand tool with keys arrayed like blades in a Swiss Army knife. The ball ended ones are very versatile, since they can be inserted from an angle rather than just straight on.

Screw driver			Slotted Phillips #2 Pozi drive Robertson #2 Torx - T15, T20, and T30	Phillips and Pozi drive look very similar but are not interchangeable. Phillips are the most difficult to ensure proper fit.
--------------	---	---	--	--

A multi bit screwdriver is a compact way of lugging around various screwdrivers. As with all fasteners ensure the bit is the same type and size as the screw. When using a screwdriver always push the screw hard into the material it penetrates even when unscrewing.

Tire pump and gauge			A hand pump with a gauge will allow you to fix slipping wheel locks more often than a wrench. You can also make the chair easier to push and the tire less likely to puncture by keeping pressures at the value marked on the sidewall. A separate gauge can be used but some people lose half the air when using it
---------------------	---	---	--

A foot pump, compressor, or special high-pressure hand pump is needed to inflate tires to values over about 50 psi. Gas stations have airlines that will fit Schraeder valves but not the skinnier Presta valve, which needs an adapter to be used. I do not recommend Presta valves for any wheelchairs - other than racing ones.

Other useful tools







Pliers	Utility knife	Nylon ties	Duct Tape	Sticky Velcro	Gloves	Hand wash
--------	---------------	------------	-----------	---------------	--------	-----------

- Needle nose pliers don't have a primary use on a chair but are useful tools that can perform a number of tasks on a wheelchair; including pulling stubborn upholstery, lining up holes, cutting tie wraps etc.
- A utility knife is also handy to have; some types have snap off blades and are easy to keep sharp.
- Nylon ties allow semi permanent fixes and help tidy loose cables.
- I don't think duct tape needs its praises sung here. However, don't use it as a long-term solution since the tape deteriorates quickly and makes a mess.
- Saran wrap (not shown) around the push handle part of a cane back facilitates upholstery removal.
- Self-adhesive Velcro™ is also useful for mounting switches and securing seating elements.
- Don't forget to keep your hands clean, some chairs can get pretty disgusting.

Understanding Nuts, Bolts, and Screws

Nuts

In this context nuts are metal bits that go on the end of a bolt. Regardless of whether a nut is metric or imperial there are three common types found on wheelchairs. Four other types that you may come across are also described.





Name	Picture	Comment
Hex nut		Most common fastener where loosening is not likely to occur. Nut thread and diameter have to be matched to the bolt in order to work.
Acorn or Cap nut		A nut with a domed top to prevent contact with the external thread. Particularly useful on footrests and armrests. Nut projects out a little, but there are no sharp edges.
Nylock nut		Very common on wheelchairs. A nylon insert at the top of the nut provides a locking feature. The nylon insert, it is claimed, helps to seal the bolt thread against seepage of water, oil, petrol, paraffin or other liquids such as urine. It is meant to be used only once. I use them as long as I can't turn them by hand.
Wing nut		A nut with 'wings' for hand tightening.
Flange nut		A nut with a built in washer, not as good as a real washer since it turns with the nut.
Jam nut		A nut with a reduced height. May be a regular hex or nylock nut.
Tee nut		A nut designed to be hammered into wood to create a threaded hole.

Bolts

Welds are used to hold parts of a structure together in a permanent way. Welding is usually the cheapest, strongest, and lightest way of connecting two pieces of metal.

Nuts and bolts are used to hold parts of the wheelchair together in a permanent or semi permanent way. Depending upon the specific wheelchair; the fasteners used may be metric (mm) or imperial (inches). Some North American chairs are imported from Europe and modified for the local market by the addition of footrests or armrests. These hybrids often have metric fasteners for the frame and imperial fasteners on the North American bits. So be warned you may have both metric and imperial nuts and bolts on the same chair, don't take anything for granted.

Bolts usually, but not always have identifying markings on the head. The most common markings indicate the strength of the bolt and also if it is metric. Never use a lower grade bolt to replace a higher one.

Imperial (SAE) Bolt	Relative Strength	Metric Bolt
 Grade 1 or 2	60	
 Grade 5	120	
 Grade 8	150	
Stainless and Titanium markings vary. Most are non-magnetic	100	Stainless and Titanium markings vary. Most are non-magnetic





Bolt size

The size of the specific bolt is indicated by a series of numbers here is the key to the code.

SAE Imperial	What it refers to		Metric
5/16 x 18 x 1-1/2	Bolt description		M8 - 1.25 - 25
5/16	Outside thread diameter (inches)	Outside thread diameter (mm)	M8
18	Number of threads per inch	Distance between threads (mm)	1.25
1-1/2	Length of bolt (inches)	Length of bolt (mm)	25

Washers

Circular discs of metal with a hole in the middle are found in many locations on a wheelchair. They protect the soft aluminum frame, perform a spacing function for camber and offsets and help to stop nuts from loosening over time.



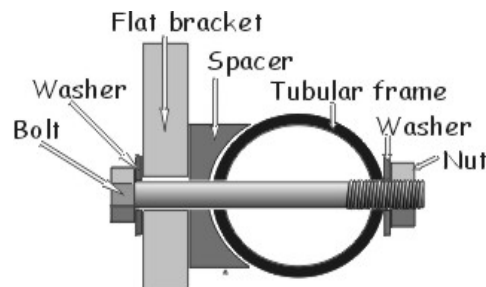

Name	Picture	Comment
Flat washer		A flat washer used to distribute load and protect softer material.
Fender washer		An oversize flat washer used to further distribute load especially on soft material.
Finishing washer		A washer used to obtain a 'finished' look. Usually used with oval head screws on upholstery.
Split lock		The most common style of washer used to prevent nuts and bolts from backing out.
Internal/External tooth washers		A washer with 'teeth'. Used to prevent nuts and bolts from backing out. Not used much on wheelchairs since it tends to chew up the soft aluminum. If used on a wheelchair protect the frame with a flat washer.

Placement of nuts bolts and washers

In wheelchairs it is not unusual to find spacers shaped in such a way that a flat bracket can be mounted to a tubular frame. In this instance the proper order for assembly is as follows:



Other fasteners you may come across

Name	Picture	Comment
Wood screw		Screws with a smooth shank and tapered point for use in wood. Found in custom seating systems.
Machine screw		Screws with threads for use with a nut or tapped hole, typically used to secure seat upholstery.
Sheet metal screw		Screws with a point for use in sheet metal. Often used to keep back sling attached to cane.
Set screw		Used to hold things in place once they are positioned properly.

Adjusting Bearings

One of the most common service tasks is to check and adjust or replace the bearings. It is at the bearing - not the wheel that actual movement occurs. Servicing bearings is relatively simple; identifying the need for service is even easier. The rewards realized from replacing a seized bearing make learning a little mechanics very worthwhile.

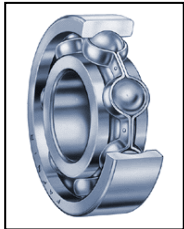

A manual wheelchair has twelve bearings. Wheel bearings (4), caster bearings (4), and caster stem bearings (4). All the bearings are straight bearings and are different to bike wheel bearings which have a cup and cone design that requires pre loading when adjusting them.

Wheel, caster and stem bearings perform different tasks and need to be treated slightly differently

Wheel bearings carry the majority of the weight and need to spin with minimal resistance. There is often a quick release mechanism built into the axle that cannot be adjusted with the same precision as fixed axles.

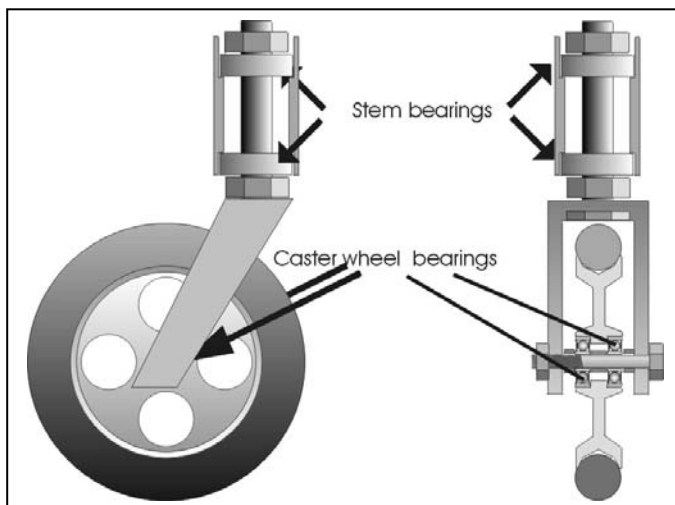
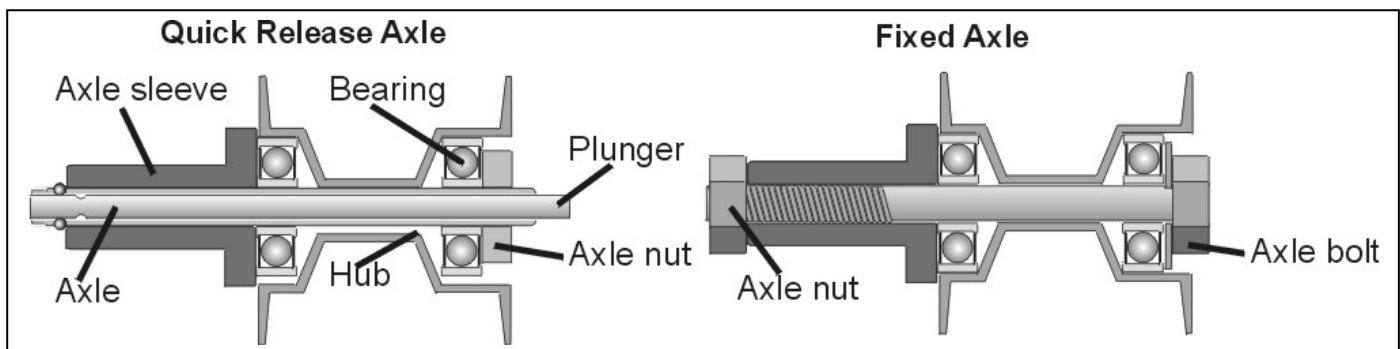

Caster bearings are like smaller wheel bearings except they are much closer to the floor and as such are most likely to pick up hair and other contaminants. The hair needs to be removed on a regular basis particularly if there are furry pets around. The easiest way to clean the caster assembly is to remove the wheel, take out the hair, wipe it off, and then reassemble. Tightening the axle nut is the same as for the wheel bearing.

Unlike wheel and caster bearings, stem bearings don't really spin, they just turn. They can be adjusted to be a little tighter than previously described for wheels. This will help to prevent caster flutter.

Some chairs use bushings at the top instead of bearings. Bushings are basically discs of low friction material, like polypropylene or bronze with a hole for the axle. They are cheaper than bearings but tend to wear quicker. A bearing can often be used to replace a worn bushing.

Testing Wheel and Caster Bearings

1. Lift one side of the chair off the ground.
 2. Spin the wheel and let it rotate freely to a stop. (This is not the wheel of fortune; a gentle spin is enough.)
 3. If it slows and stops dead it is too tight.
 4. If the wheel slows and rotates backwards slightly the bearing is not being compressed, however it could be too loose.
 5. Grasp the tire and wiggle it in and out to see how much play there is at the axle, less is better.
- NB. Quick release wheels will always have a little play.

Removing and Installing Wheel Bearings

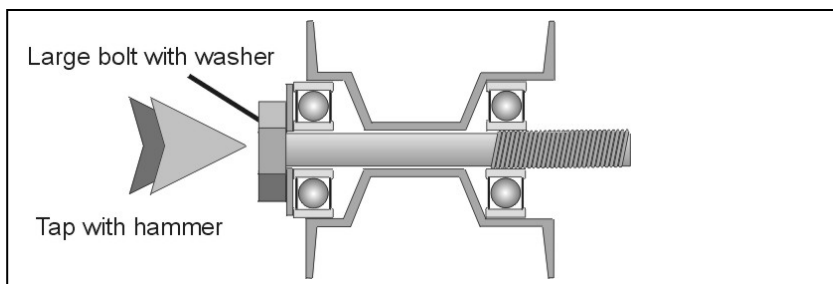
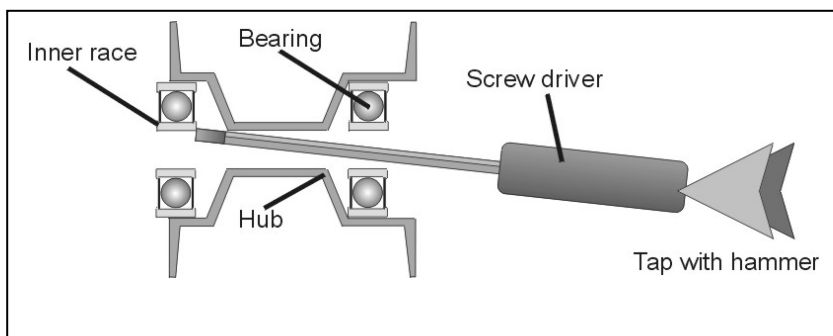

1. If you are replacing bearings you can use a screwdriver to knock out the old ones. However, a screwdriver can damage the inner race. If you intend to reuse the bearings find something with a more forgiving end or be gentle and tap all the way around the race, easing the bearing out slowly.
2. Repeat for the other side
3. Seat the new bearing using the largest bolt that fits in the axle hole and a washer big enough to reach the outer race.
4. Repeat for the other side.
5. Go to step 2 in the testing section.
6. Adjust the axle play to the smallest amount possible

Adjusting Axle Play (fixed axle)

1. Tighten the axle bolt until the wheel does not spin freely.
2. Back off $\frac{1}{4}$ turn at a time and spin the wheel until it just counter rotates after stopping.
3. Tighten the axle nut.

Adjusting Quick Release Axles

1. Check the play in the wheel and make sure it spins freely.
2. To adjust the play the wheel must be removed.
3. The axle nut is $\frac{3}{4}$ " and is easiest to adjust with a socket.
4. The axle has to be held with either a $\frac{7}{16}$ " wrench on the flat spots near the other end or a $\frac{1}{2}$ " wrench in line with the balls.
5. Keep tinkering with the length of the axle until the wheel has the least amount of side play when the plunger still pops out.

Compromised bearings can significantly increase the energy required to propel a manual chair. The slow onset of bearing deterioration makes it a very common occurrence because the user doesn't recognize the microscopically small increases in energy expenditure from day to day. Half an hour and \$100 worth of bearings can make an incredible difference to someone's manual wheelchair propulsion efficiency.

Wheel Lock Adjustment

Wheel Locks used to be called brakes until a lawsuit was launched by someone who used the device to slow themselves down and fell out of their chair. They could have been called parking brakes but wheel locks won.

This information only covers wheel locks that work by putting pressure directly on the tire but since that covers about 98% of the wheelchairs you are likely to see it should be enough. Other wheel locks are available that act on the hub either directly or via a cable and or disc. They are uncommon and not covered here.

Types of Wheel Lock

In this class, while there are a number of variations, it boils down to two main and two sub types:-

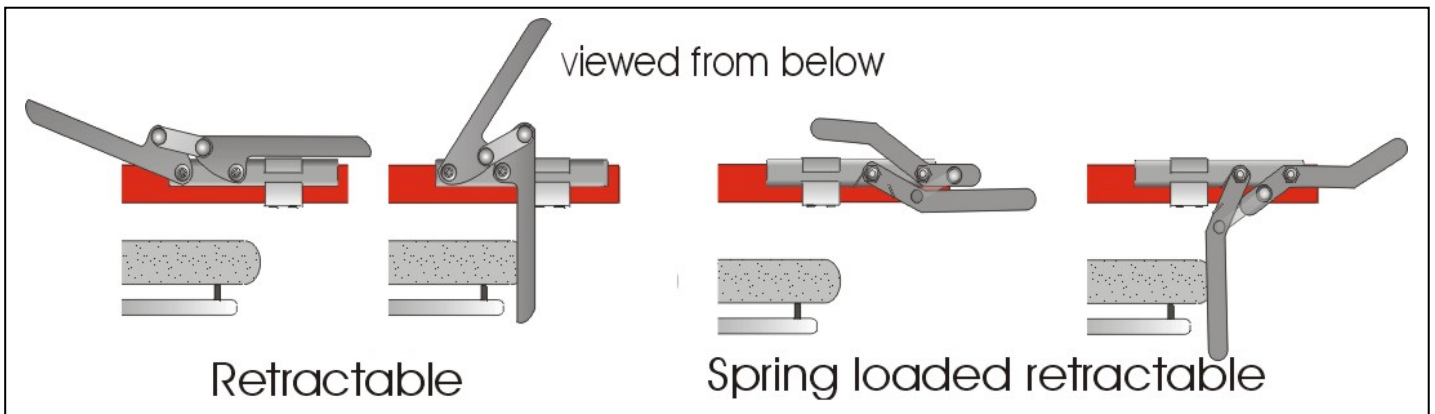
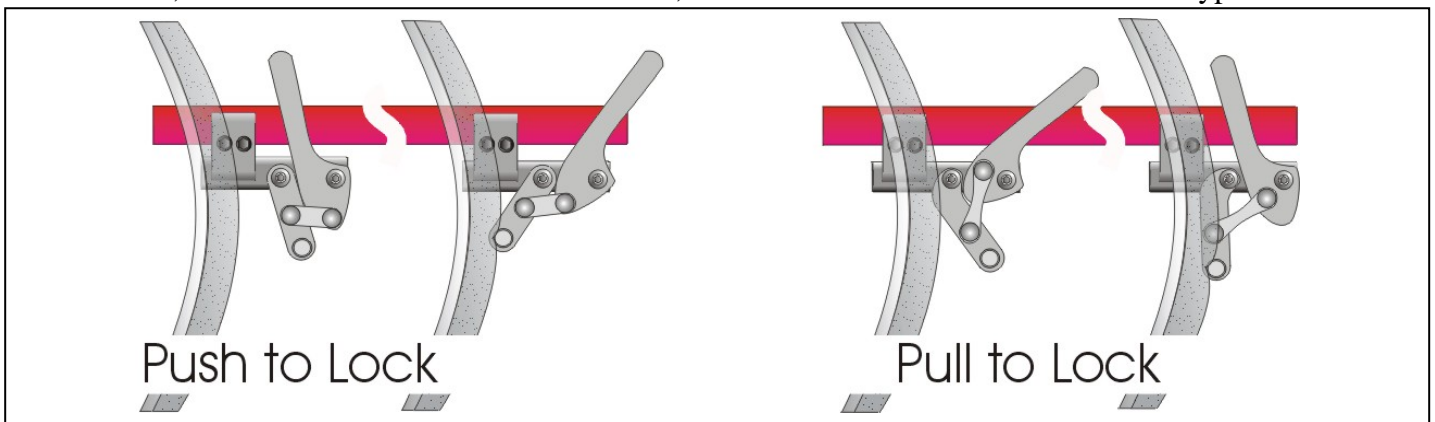

Reasons for wheel locks not working	Solution
Pneumatic tires deflated	Inflate tires
Worn down solid tires	Replace tires and /or adjust wheel lock position
Worn friction bar on lock	Adjust wheel lock position
Axle position was adjusted	Adjust wheel lock position
New wheels and / or tires	Adjust wheel lock position
Wheel lock linkage sloppy	Adjust linkage tension

With pneumatic tires always check inflation. Recommended pressure is marked on the tire wall.

Adjusting wheel lock position

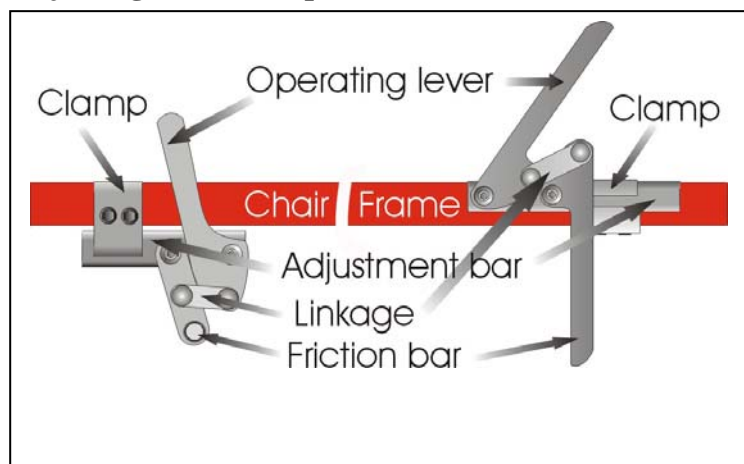

1. Apply the wheel lock using the operating lever and determine how far the friction bar needs to move.
2. Release the wheel lock.
3. Loosen both bolts securing the clamp to the chair frame.
4. Slide the adjustment bar the appropriate amount.
5. Tighten the bolts
6. Apply the wheel lock.
7. Check to make sure the wheel doesn't rotate and the chair user can operate it.

Adjusting the Linkage Tension

Most wheel locks have four pivot points. There are two on the adjustment bar and two on the linkage that connects the operating lever to the arm that applies friction to the tire. All pivot points have to allow free movement in one plane only. On better wheelchairs a low friction washer is used between each metal component. As the components wear they can either seize up or get sloppy depending on circumstances. In either case cleaning, lubrication, and adjustment will help.

The two pivot points on the adjustment bar are generally bolts and nylock nuts. The two pivot points on the linkage can be either bolts and nylock nuts, or rivets. If they are rivets they cannot be adjusted. If they are bolts they can.

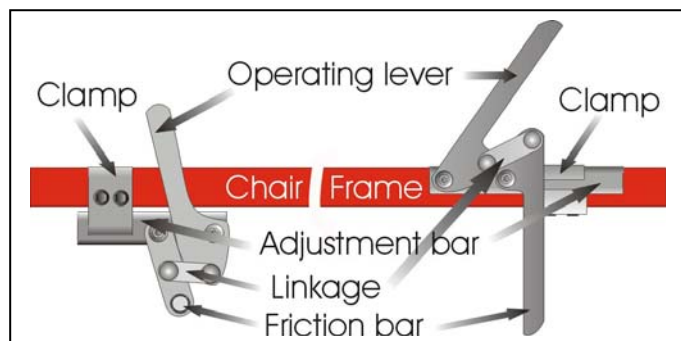

1. Loosen bolts.
2. Spray anti-friction washers with a Teflon™ lubricant and wipe off the over spray.
3. Tighten bolts until snug.
4. Back off a little at a time until the mechanism moves with minimal resistance.
5. Adjust the wheel lock as described earlier.

If the wheel locks become sloppy quickly, replace the nylock nuts and / or use Loctite on the bolt threads.

Tracking Adjustment

Wheel camber is the name given to a situation where the wheels viewed from the front are not parallel. Camber has a number of benefits as well as drawbacks. Toeing error is the name given to a situation where the wheels viewed from above are not parallel; toeing error has no benefits, only drawbacks. Toeing error is the same as camber except rotated through 90 degrees.

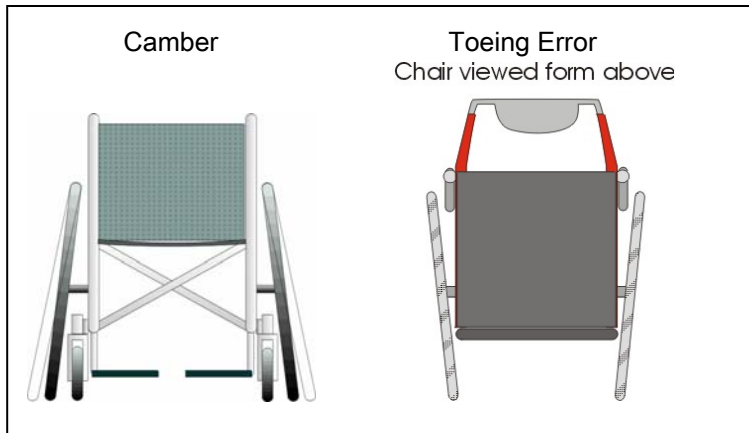

Benefits of Camber

- Decreased tendency to turn down hill
- Hand protection through doors
- Increased stability turning at speed
- More natural shoulder action

Drawbacks of Camber

- Chair wider
- Toeing error in wheelie position
- Slight increase in tire and bearing wear

In theory, without camber a wheelchair would never need to be checked for toeing error regardless of the adjustments made. But since we discovered the benefits of camber; pretty well all high-end chairs have a number of different camber settings available. With the availability of camber comes the need to compensate for toeing error that may be induced by a change in wheel height or seat angle. Since there is a mechanism for correcting it, the same mechanism, if left out of adjustment can create it.

One degree of toeing error increases energy expenditure by 50% and 2 degrees = 150%. Toeing error should be checked and minimized on all chairs. Even if you don't get the wrenches out to fix this problem simply alerting the client to it can save him loads of shoulder wear and tear if he takes time to have it fixed.

Measuring

1. Make sure the chair is on a flat smooth surface.
2. Measure the vertical height of the axle from the ground.
3. Draw a mark on the tires at the same height. Or move the wheel until the valve is there.
4. Measure the horizontal distance between the insides of the tires at the height of the mark.
5. Rotate both wheels through 180 degrees so the mark is at the correct height from the ground again.
6. Measure the horizontal distance between the insides of the tires at the height of the mark.
7. Compare your results from step 4 and 6; they should be identical. If not go on to the adjusting section.

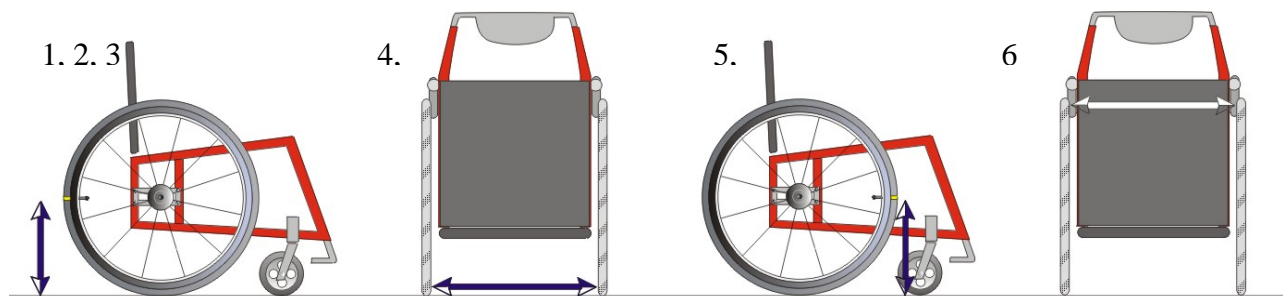

Adjusting toeing on a chair with a camber bar.

1. Rotate the wheels so the marks are axle height from the floor at the back.
2. Loosen the bolts holding the camber bar.
3. Rotate the bar until the wheels are parallel. (If the camber bar has a built in spirit level; simply rotate the bar until the bubble is in the middle.)
4. Check the width at the back. E.g. if you measured 24" and 25" for step 4 and step 6 (above) respectively you had a 1" toeing error.
5. The error can be eliminated by rotating the bar until the distance is 24.5"
6. Check to make sure the wheel locks still work.

Adjusting toeing on a chair with a camber plate.

This is way more involved than adjusting a camber bar equipped chair. Allow yourself at least half an hour for the job. You will need two sets of washers adding up to 1/8" thick each. The aforementioned measurements suggest the chair is toed out. You will therefore need to move the camber plate out at the back by placing washers between the spacer and the plate. Work only on one side at a time so you have a reference to help you remember where everything goes.

1. Lay the chair on it's side.
2. Remove the upper wheel.
3. Loosen the two nuts securing the camber plate at the front.
4. Remove the two nuts at the back of the camber plate and pull the bolts out. Take care not to displace any washers already in place.
5. Add the appropriate number of washers between the camber plate and spacer.
6. Reassemble, taking care to snug up all four nuts equally before tightening them.
7. Make sure you have no parts left over; use the untouched side as your reference.
8. Now do the same thing to the other side.
9. Measure the toeing. (If it is still off - go to step 1. and feel free to curse)
10. Adjust the wheel locks.

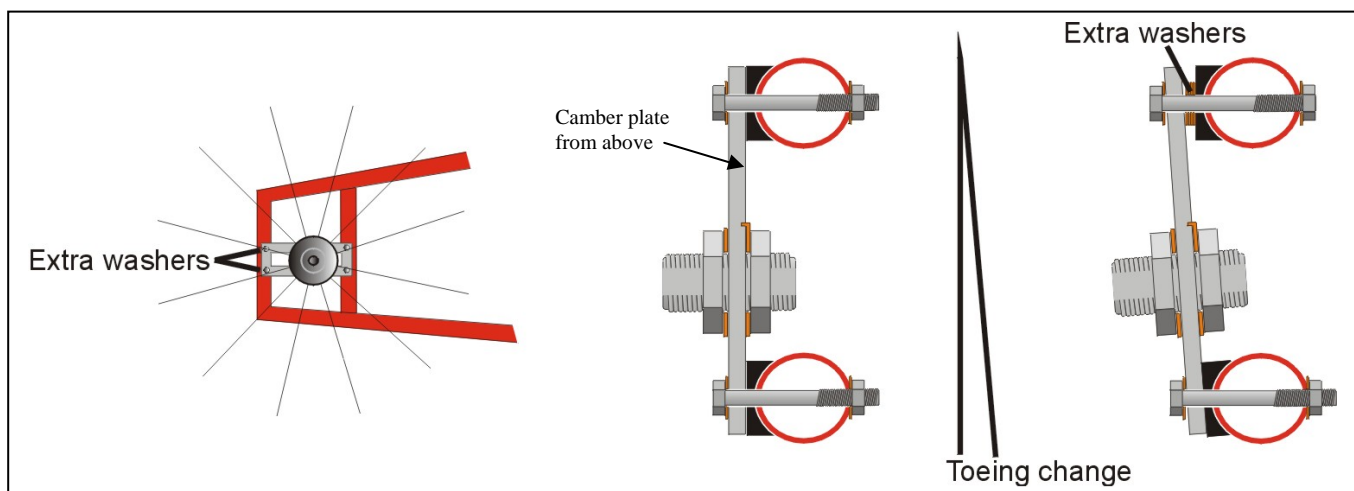

Caster Stem Adjustment

Caster stems that are not vertical cause a number of problems. If the stem leans forwards at the top (middle diagram) the chair is difficult to turn and the knees are lower wheeling forwards than when wheeling backwards. If the stem is leaning backwards at the top, the chair is difficult to keep in a straight line and the knees raise up higher when rolling forwards. Also whenever the wheeler stops the chair will roll backwards a little.

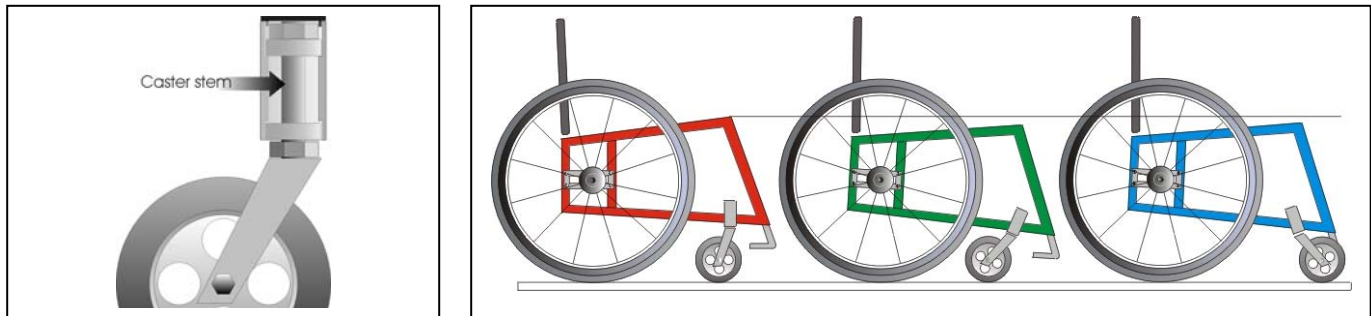

Changes that can affect caster stem angle include:-

Rear wheels

- Changing wheel size
- Significantly changing camber
- Moving up or down on camber plate to change seat angle

Casters

- Changing fork or wheel
- Hitting an obstacle

Caster stems must be kept as vertical as possible. Some chairs do not allow any angle adjustment, relying on different length fork and caster wheel size to keep the stem vertical. Of the chairs that do allow for angle adjustment there are a number of different ways of accomplishing the task. There are also a number of different ways to test if the stem is vertical.

Tools

All methods of measuring caster stem angle require that the floor is flat and level. Then a reference point on the caster fork and or stem housing is compared to see if it is either perpendicular or parallel to the floor.

Tools commonly used include:-

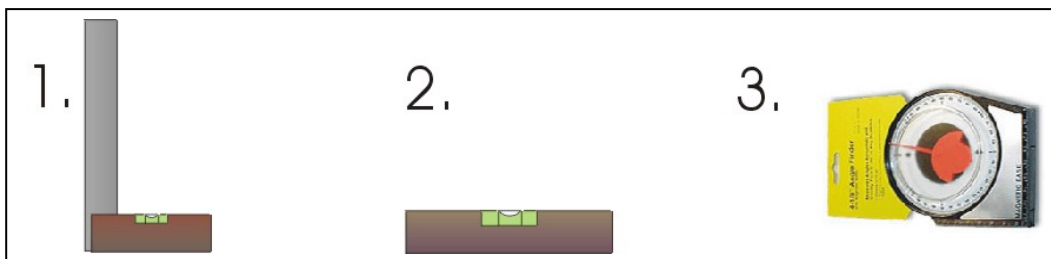

1. Tri square
2. Spirit level
3. Angle finder

This is not an exhaustive list; there are other tools that can be used to indicate the angle of the stem relative to the ground.

Measuring

- Ensure the chair is on level ground.
- Identify a surface on the caster stem or caster fork that is either parallel or perpendicular to the stem.
- Measure the deviation from vertical or horizontal.
- Repeat for the other side.

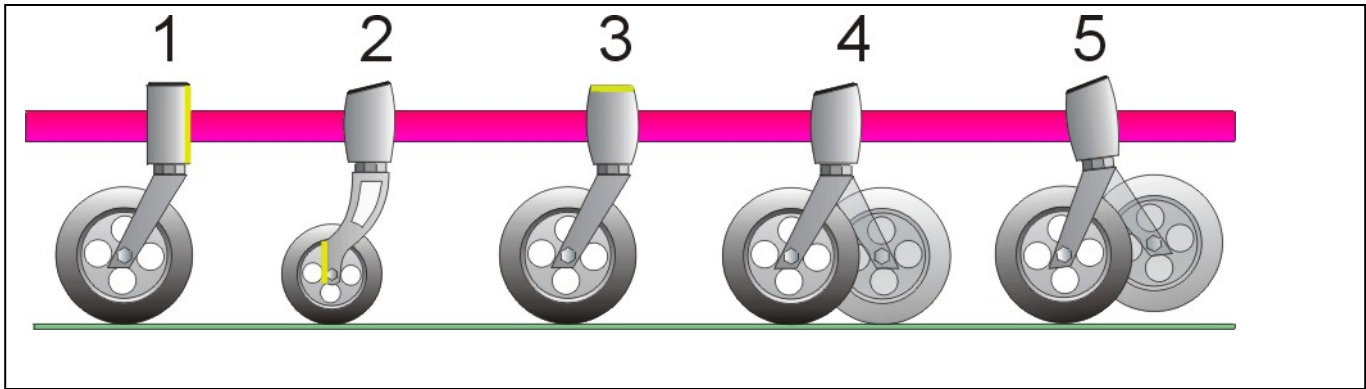

Example 1 – The caster housing should be vertical.

Example 2 – The trailing edge of the fork should be vertical.

Example 3 – The top of the caster housing should be horizontal.

Example 4 & 5 – When there are no obvious horizontals or verticals; rotating the caster 180 degrees from the trailing to the leading position is an easy way to tell if the stem is vertical. The caster wheel should always be just touching the surface. If the stem is not vertical the wheel will lift or the front of the chair will rise up. (5)

Adjusting

The exact method of adjusting caster stem angle varies depending on the particular model.

Off centre bolt, washer, or ridged plate

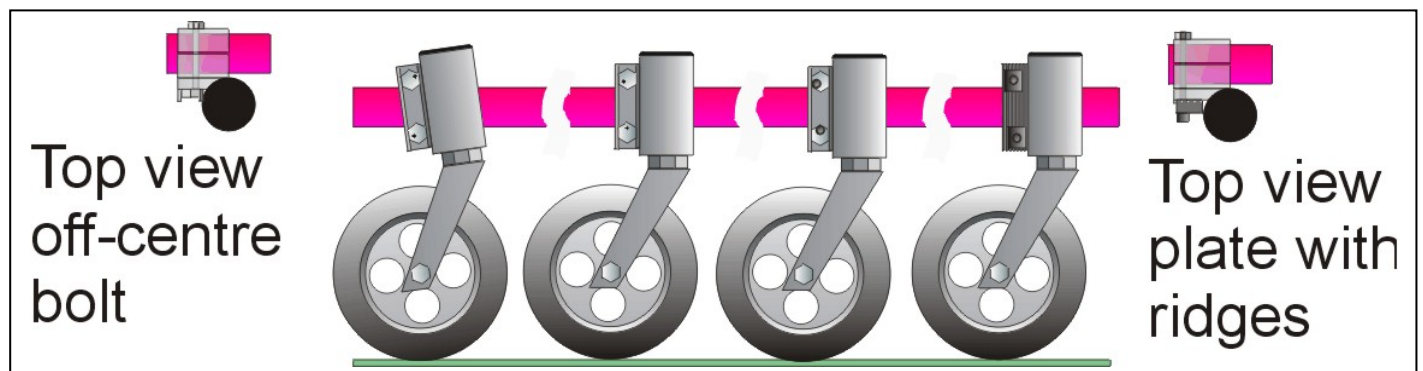

Either a bolt with an off centre shaft, a washer with an off centre hole, or a plate with ridges is used to accomplish caster stem alignment.

1. Loosen the nuts on the inside of the caster stem mounting bracket.
2. Rotate the top and bottom bolts, washers or move the plates until the stem is as close to vertical as possible.
3. Tighten the nut and check the alignment.
4. Repeat on the other side

Clamp Style

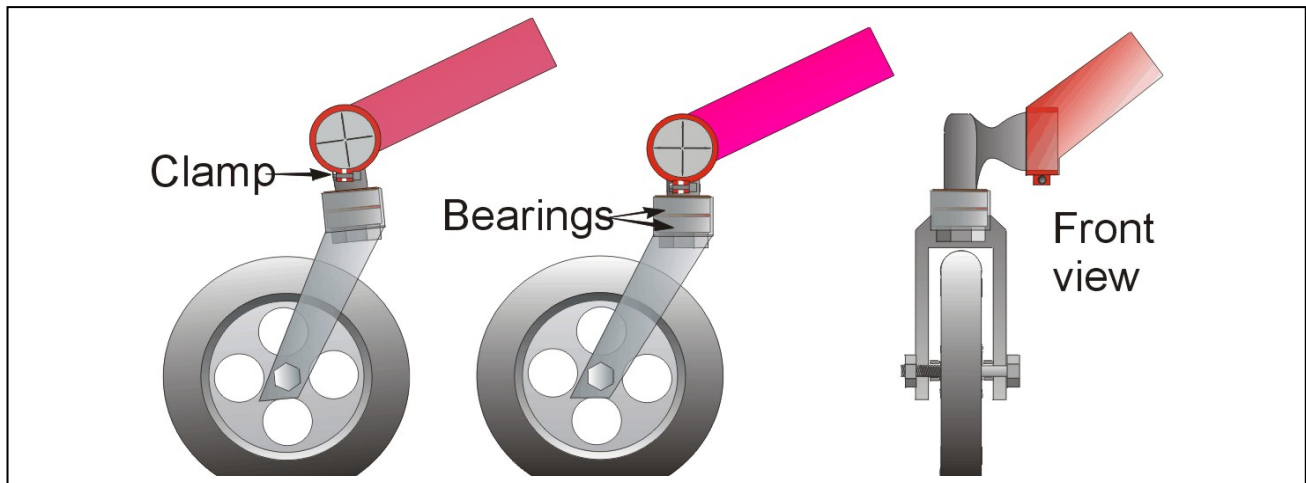

1. Loosen the nut clamping the caster to the frame.
2. Rotate the caster assembly until the stem is vertical.
3. Tighten the nut and check the alignment.
4. Repeat for the other side.

Tooth Style

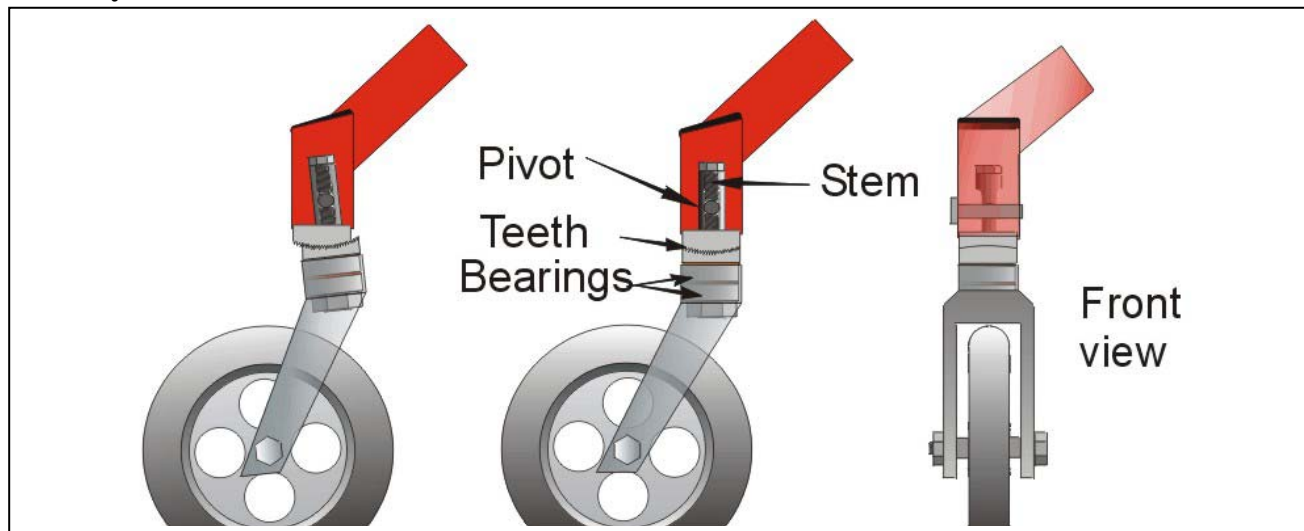

1. Remove the dust cap from the top of the caster stem housing.
2. Loosen the bolt sufficiently to let the teeth become disengaged from each other.
3. Rotate the caster assembly until the stem is vertical.
5. Tighten the nut and check the alignment.
4. Repeat for the other side.

There are other mechanisms by which the caster stems are adjusted. If you are ever in doubt as to how they work keep one side intact so you always have a reference to refer to for reassembly.

Lubrication

Cleaning

Wheelchairs really benefit from a good cleaning. Mild soap and water is recommended for the frame and non-absorbent bits. In fact you can clean it as you would a car. Finishing with car polish will add a layer of protective wax to help it to stay clean. If the chair hasn't been cleaned in ages dampening it for a while should soften the accumulated grime. Remember water isn't going to hurt the chair unless it stays wet for days on end. Upholstery can be wiped down with a damp cloth or use fabric cleaning liquids. Cushions need to be dealt with according to the manufacturers' guidelines.

Lubricate where two parts of a chair move relative to each other. Dry lubricants like Teflon™ and graphite tend to be the most user-friendly. They leave a dry film on the material that displaces water, inhibits corrosion, and provides a smooth slippery interface between the two surfaces. Most are compatible with the plastics and metals found on wheelchairs. Teflon dries clear and graphite dries black. Owner's manuals will give a comprehensive list of areas to lubricate.

Over-lubrication can be a problem on wheelchairs. This occurs when too much grease or oil is applied. Dirt, hair and other nasty stuff sticks to the surface and can actually do more harm than good by trapping abrasive particles, not to mention getting the icky stuff on clothing. Whenever lubricants are used bear this in mind and wipe off over spray.

Quick release axles

If the wheels are not removed on a regular basis the axles tend to seize up. Maintenance of these items is very easy. It needs only to be done on a monthly basis at most.

1. Remove the axle.
2. Wipe it off with a cloth dampened with WD40.
3. Lubricate with dry Teflon™ spray or if you only have WD40 use it and wipe off the extra. (You can even use Pam cooking spray if you have nothing else.)
4. Dampen a cloth with WD40 and wipe off any accumulated dirt from the bearings.
5. Replace the wheel and ensure the quick release plunger extends fully to secure the wheel.

Bearings



Almost all wheelchair bearings are sealed bearings, which keep out foreign bodies and keep the lubricant inside. The lubricant eventually breaks down and at that time bearing wear increases dramatically.

Spraying WD 40 on the outside of a bearing and wiping it off will not hurt the bearing and will help clean it. Smearing grease on the outside will not help the bearing, it will however attract dirt and abrasive material, which could damage the bearing and certainly make the chair less appealing.

If you want to lube a bearing you have to very carefully remove one of the seals (black bit) using a sharp pointy tool like a pin or knife to expose the cage (shiny bit). Wash the bearings in a solvent and let thoroughly dry before repacking with grease and replacing the seal. Do not use WD40 as a lubricant for bearings, it is too thin and will actually accelerate bearing wear. You can use it as a solvent to clean out the old grease though.

Fixing a flat tire

The only drawback to pneumatic tires is they can lose their air. This occurs either over time, or due to a puncture. Air loss occurs naturally at a rate of about 50% in two months, the loss is through the walls of the tube not the valve. If air is lost at a quicker rate you have a puncture.

Most pneumatic wheelchair tires are clinchers, which means they use an inner tube, the air in the tube presses the tire onto the rim and the pressure holds it in place. Air enters the tube through a valve, of which there are two kinds, Schraeder and Presta. The inside of the rim is covered in rim tape so that the nipples of the spokes don't poke holes in the tube. The edges of the tire are lined with wires to hold onto the rim; this is called the bead. The tire must be removed from the wheel to test and fix the tube.



Schraeder valve



Presta valve



Presta valve with adapter

Different Kinds of Flats

A sharp object that sticks in your tire and punctures the tube causes most flats. The second most common type is caused by a pinch, these are called snakebite flats. Snakebites occur when hitting a curb with too little air in the tube. Occasionally a valve leaks and the valve core has to be replaced. If the tube explodes due to an old, weak, or poorly fitting tire the tube and tire must be replaced.

Tools



- A pump compatible with the valve. We recommend Schraeder valves.
- A tire pressure gauge, one built into the pump is the most convenient.
- Tire levers, which help lift the tire bead over the rim
- A patch kit, with extra patches, rubber cement, and a piece of sandpaper or a buffer

Tire and tube removal

1. Mark the tire next to the valve to help locate the puncture later.
2. Let all the air out of the tire by pressing the little stem in the middle of the valve. (If you have a Presta valve unscrew the top and press it in).
3. Release the bead from the rim all the way around (it tends to stick). Then push the beads in towards the rim well.
4. Unscrew the nut holding the valve to the rim (if it has one).

5. Use the tire levers to ease the tire off the rim. If you can do it without levers that is better. Don't use a screw driver because it will damage the rim and may make another hole in the tube.
6. Pull the tube out of the tire.

Fixing the tube

1. Inflate the tube using the pump.
2. Hold the tube close to your face and listen and feel for the air escaping. This is easier than looking. If you cannot find the puncture submerge the tube in water and you will see the bubbles of escaping air from the puncture.
3. When you find the puncture, scrape the area around it with the buffer (sand paper). This cleans the rubber and roughens it so that it takes the patch better; it also marks where the puncture is so you can find it again when the tube dries.
4. Let the majority of the air out. Cover the area with rubber cement (from the patch kit); make sure that the area covered is greater than the size of the patch. Larger holes need bigger patches. Wait about five minutes for the cement to dry.
5. While the cement is drying, look for the sharp object that caused the puncture. If you use the mark you made on the tire to see how the tube was lined up with the tire, it shouldn't be hard to figure out which section has the offending object in it. Take a piece of cloth and run it along the inside of the tire; it will stick on the protruding object that punctured the tube. Remove the object.
6. When the cement is completely dry. Peel the silver foil off the patch and apply that side to the tire. Rub hard from the centre toward the edges so that it sticks really well. Leave the cellophane on; it can be tricky to remove without damaging the patch and it helps protect the patch.
7. Dust the excess glue with talk or chalk to stop it adhering to the tire.

Replacing the tube and tire

1. Make sure the tape is in place around the rim, it protects the tube from the spoke nipples.
2. Inflate the tube slightly and pack it back into the tire, pushing the valve through the hole in the rim. Make sure the valve stays perpendicular to the rim.
3. Now slide the bottom bead over the rim, this should be easy to do.
4. Ease the second bead over the rim working your way around on both sides towards the opposite side.
5. The last part of the bead will be very difficult to lift over the rim. Make sure the bead where you started is pushed way in to the rim, this will give you a little more slack. Gradually work the top bead up and over the rim taking care not to pinch the tube. If you do, you will have to go back to square one. If possible try to complete this without using the tire levers to reduce the likelihood of damaging the tube. A little Armor All on the sticking bead can help ease things.
6. When the tire is on, push both beads into the well of the rim all the way around the wheel to make sure the tube isn't pinched.
7. Inflate the tube to the pressure marked on the sidewall.
8. Tires have a reference line that should be the same distance from the edge of the rim all the way around; this ensures the tire is seated properly on the wheel. If it is off centre let air out adjust the tire on the rim and re-inflate.